RATIONALISED PROTOCOL

REVISION 6

For fall restraint systems on fluted metal roof sheeting

8 June 2026

Developed for industry and approved by the

INSTITUTE FOR WORK AT HEIGHT



And the

SOUTHERN AFRICAN METAL CLADDING AND ROOFING ASSOCIATION



Contents	Page
• i Introduction	2
• ii Scope	2
• 1 References	2
• 2 Terms, general definitions and obligations.....	3
• 3 Requirements	4
• 4 Specific Requirements	6
• 5 Test Methods	7
• 6 Installation	13
• 7 Securing Methods	14
• 8 Information to be supplied	14
• 9 Documentation control.....	15
• 10 Determination of base static load	15
• 11 Establish restraint load	19

i) Introduction

Fall protection focuses on the health and safety of persons at work in elevated positions. There are several standards, technical specifications and guidelines covering the design, testing and installation of such systems on suitable loadbearing structures and substrates that can be designed to withstand the high shock loads resulting from fall arrest incidents.

This standard is intended to address the issues on fluted metal roof sheeting which cannot normally withstand fall arrest shock loads. The proliferation of roof mounted Photo-Voltaic panels, solar geysers and other services on metal roof sheeting and the safety of persons working on these roofs are addressed in this document.

Close cooperation between sheeting profilers, building structure designers and the manufacturers of fall restraint systems is required to ensure that the effect of fall restraint loads on fluted metal roofing and supporting structures are addressed in a cohesive manner to ensure the integrity of the roof sheeting and the wellbeing of the persons using the fall restraint systems. Financial contributions towards the testing process are to be negotiated between the parties.

ii) Scope

The scope and requirements are based on the philosophy that anchor devices and the supporting structure are rated to sustain the static forces generated under fall restraint conditions.

This South African protocol specifies the requirements for performance and associated test methods for single and multi-user anchor devices and systems which are intended to be used in a fall restraint environment. Multi-user refers to a maximum of 2 persons.

This protocol is not applicable to fall arrest anchor devices and systems that conform to international fall arrest standards, specifications and guidance notes.

1 References

- 1.1 SANS 50354 (EN 354) Personal protective equipment - Lanyards
- 1.2 SANS 50358 (EN 358) Personal protective equipment - Belts for work positioning and restraint and work positioning lanyards
- 1.3 SANS 50361 (EN 361) Personal protective equipment - Full body harnesses.
- 1.4 SANS 50362 (EN362) Personal protective equipment - Connectors
- 1.5 SANS 50365 (EN 365) Personal protective equipment - Instructions for use, maintenance, periodic examination, repairs, marking and packaging.
- 1.6 SANS 10237 The design, testing and installation of self-supporting metal cladding.

2 Terms, general definitions and obligations

- 2.1 **Anchor device** - an assembly of elements which incorporates one or more anchor points that can include a fixing element as the interface between the anchor point and base material, can be used as a static anchor point or as part of a fall restraint system.
- 2.2 **Base material** - roof sheeting and support structures such as purlins and associated bracing where applicable. The profile, thickness, material and fixing method of the sheeting as well as purlin material, size, shape and spacings are to be specified by the sheeting profiler in cooperation with the building structure designer.
- 2.3 **Bay length / span** - the distance between extremity anchors in single span flexible anchor lines or between extremity and intermediate or between intermediate and intermediate anchors in multi-span anchor lines, measured between the centre line of anchors. The maximum bay length on fluted metal sheeting shall be restricted to 7,0m.
- 2.4 **Competent person** - a designated person with the proven skills, knowledge and experience in a specific area of expertise and certified as such by a recognised constituent body
- 2.5 **Load limiting device** - element of the anchor line system that either dissipates the kinetic energy through deformation or stores the elastic potential energy developed during fall restraint.
- 2.6 **Extremity Anchor** - element that connects the end of a flexible anchor line or rigid anchor rail to the base material.
- 2.7 **Fall restraint** - fall protection system and associated personal protective equipment which prevents the user from reaching zones where the risk of a fall from a height exists.
- 2.8 **Inspection** - careful examination or scrutiny of components and elements of fall restraint systems to ensure compliance with the manufacturer's specified state of the device or element in question.
- 2.9 **Intermediate anchor** - element located between the extremity anchors connecting the flexible anchor line or the rigid anchor rail to the base material.
- 2.10 **Manufacturer** - the original fall protection equipment manufacturer (OEM) that is responsible for the design, fabrication and/or assembly of elements and components into anchor devices and conducts the required tests of the assembled fall restraint systems and devices in their allowable configurations. Responsible for determining the performance characteristics of the systems. Tabulating or otherwise categorising allowable configurations and where applicable, minimum and maximum lengths of anchor lines, bay lengths and anchor rails support spacings. Providing all the necessary information to allow competent installers to assemble, erect, install, commission and inspect such systems.
- 2.11 **Owner** - the registered owner of the building / structure or the appointed agent acting on behalf of the owner of the building or structure containing the fall restraint system. Note that this agent is not the Construction Health and Safety Agent that might be appointed in terms of the Construction Regulations for the duration of the construction of the building.

- 2.12 **Periodic examination** - thorough examination at set intervals to determine the on-going safe-to-use status of fall protection systems leading to early detection of problems and planned preventative care. These examinations are to be carried out by designated competent individuals.
- 2.13 **Pre-tensioning** -required in anchor lines to reduce the slackness in the lines and to manage induced forces during restraint events. Pre-tension is a measured amount of tension in the line set during ambient temperature ranging between 15°C and 20°C to reduce the construction stretch in the anchor line. The loads are based on Dia 8mm multi-strand steel wire ropes. A combination of rope lengths and bay lengths determine these loads.
- 2.14 **Roof sheeting profilers**- Profilers and suppliers of SABS aligned fluted metal roof sheeting, either pierced-fix or concealed-fix profiles, and the fall restraint manufacturers must take cognisance of SANS10237 "*The design, testing and installation of self-supporting metal cladding*" which requires additional tests to cover plant and other equipment not forming part of the cladding system.
- These additional test shall be subject to a separate design consideration. This process is to be undertaken before subjecting sheeting to the static fall restraint load tests. After all tests have been concluded to the satisfaction of the roof sheeting profilers, they will provide the fall protection system suppliers with conformance certification for specified fall restraint systems which will include all the limitations and other conditions as stipulated by the profiler.
- 2.15 **Structural Anchor** - combination of one or more permanent fixing elements, not intended to be removed and used to connect the anchor device to the base material.
- 2.16 **Supplier** - Entity or organisation that accepts responsibility in terms of section 10 of the Occupational Health and Safety Act for the supply and installation of the fall restraint system.
- 2.17 **Traveller / Shuttle** - element with an anchor point that travels along a horizontal anchor line.
- 2.18 **User** - person that is medically fit to perform the identified work tasks, is trained and certified against a skill programme for working at height with specific focus on fall restraint systems and procedures.
- 2.19 **Work positioning** - work method and equipment that enables the user to work in tension or suspension in such a way that a free fall is prevented.

3 Requirements

3.1 General

- 3.1.1 Anchor devices must be designed to be removed from the structural anchor without damage to the device or structural anchor allowing for its reuse, maintenance or replacement
- 3.1.2 U-bolt clamps shall not be used to form terminations in any part of the structural anchor or anchor device.

- 3.1.3 It shall not be possible for elements of the anchor device to become detached unintentionally. If the element or anchor device can be removed, it will be designed to require two separate, consecutive and deliberate manual actions.
- 3.1.4 Anchor devices must be designed to allow the connectors to rotate freely to align the anchor point in the expected load-bearing direction /position.
- 3.1.5 Anchor devices that consist of more than one element and anchor devices that can be adjusted shall be designed so that the elements cannot appear to be positively locked together when incorrectly assembled or adjusted.
- 3.1.6 The maximum mass of any element or device that is intended to be transported by a single person shall not exceed the mass indicated in the project specific risk assessment and in the absence of a risk assessment should not exceed 25 kg.
- 3.1.7 If the anchor device is fitted with an energy-dissipating element, such element will include a visual indicator of the element's activation requiring that the element be replaced.
- 3.1.8 Any anchor device that can be used as either a static single point device or as forming part of a mobile anchor line shall be tested for each application.
- 3.1.9 Anchor devices shall be tested in all safety critical directions of use as defined by the manufacturer.

3.2 Materials

- 3.2.1 All components of anchor devices shall be protected against corrosion, and the operation of moving elements shall not be adversely affected by corrosion.
- 3.2.2 Measures shall be taken to prevent Galvanic corrosion of elements of an anchor device made from dissimilar metals where permanent contact between these items and also between the device and the base material is anticipated.
- 3.2.3 Non-metallic elements shall be manufactured from suitable materials as indicated in the relevant personal protective equipment standards.
- 3.2.4 All connectors between the anchor device and personal protective equipment shall comply to SANS 50362.

3.3 Ergonomics

- 3.3.1 Anchor devices shall not have sharp edges or burs that may cause injury to users or that may cut, abrade or otherwise damage itself or any part of personal protective equipment that it may come into contact with.
- 3.3.2 The design and arranging of the anchor device shall take note to the requirements of ergonomic risks and adverse health effects as per the Occupational Health and Safety Act's (Act 85 of 1993) Ergonomic Regulations of 2018.

4 Specific Requirements

4.1 Static Anchor devices (single anchor point)

- 4.1.1 When tested in accordance with 5.2 (deformation test) anchor devices that are intended to deform to absorb energy shall not deflect by more than 5 mm at anchor point position in the direction of loading but shall not display any permanent deformation after the test load is removed.
- 4.1.2 When tested in accordance with 5.3 (static test) the device may deflect within its elastic limit but shall not deform permanently nor shall it release the load.

4.2 Horizontal flexible anchor lines

- 4.2.1 When tested in accordance with 5.2 (deformation test) extremity, intermediate, corner anchor devices and the traveller that are intended to deform to absorb energy shall not deflect by more than 5 mm at the anchor point whilst under load in the direction of loading, but shall not display any permanent deformation after the test load is removed.
- 4.2.2 Performance predictions based on calculations or test results shall be available for each allowable configuration of the anchor line indicating:
 - 4.2.2.1 Maximum line deflection at the traveller in the direction of loading.
 - 4.2.2.2 Maximum load expected at the extremity anchors, intermediates or corners that are in-line fittings or on anchor lines without extremity ends (circular continuous lines) the maximum load in the anchor line.
- 4.2.3 When tested in accordance with 5.5 or 5.7 (static test) the values as per 4.2.2 shall not vary by more than $\pm 20\%$ from those predicted.
- 4.2.4 All metallic, load bearing components including the flexible anchor line and terminations shall be capable of sustaining twice the maximum loads to which each is exposed. All non-metallic elements, if evidence of durability is not provided, shall sustain at least three times the maximum load to which they are exposed.
- 4.2.5 When tested in accordance with 5.5 or 5.7 (static test) the traveller shall not become detached from the anchor line. No part of the system shall break.
- 4.2.6 Where an anchor line is fixed at intermediate or corner anchors i.e. prevented from sliding through these anchors, each line will be considered to be independent lines and shall be tested accordingly.

4.3 Horizontal Rigid Anchor Rails

- 4.3.1 When tested in accordance with 5.8.1 (deformation test) the rail shall not deflect by more than $\text{span} / 500$ in the direction of loading and its fixing brackets shall not deflect by more than 3mm. Such deflection shall be within the elastic limit of the material used in its manufacture and no part of the system shall permanently deform.
- 4.3.2 When tested in accordance with 5.8.2 (static test) the device shall not release the load.

- 4.3.3 When tested in accordance with 5.8.2 (static test) the deflection of the rail between support points shall not exceed span/350 in the direction of loading and such deflection shall be within the elastic limit of the material used in its manufacture. No part of the system shall permanently deform or break.
- 4.3.4 The rails shall have end stops to prevent accidental detachment of the traveller/s. Detachment will require special tools and deliberate actions by a competent person.
- 4.3.5 All metallic, load bearing components including the anchor plates, rail joints, junctions and terminations shall be capable of sustaining twice the maximum loads to which each is exposed.

5 Test methods

5.1 General

- 5.1.1 Install anchor device in accordance with manufacturer's instructions.
- 5.1.2 Apply static loads in each principal configuration and direction that may occur in service necessary to ensure that the anchor device is safe for use.
- 5.1.3 Where successful deformation tests precede the static tests, separate anchor devices need not be used.
- 5.1.4 Verify appropriate documentation and /or visual/ tactile examination that the anchor devices meet the requirements of 3.1, 3.2 and 3.3.

5.2 Deformation Test

- 5.2.1 Mount the relevant element i.e. anchor device, extremity anchor, intermediate anchor, energy dissipating / storage device or traveller on a rigid foundation (concrete) and subject it to a load of 1,0kN for 3 minutes in the direction of load as per manufacturer's instructions and measure the deflection.
- 5.2.2 Release the load and check for any deformation.

5.3 Static strength test - Anchor Device

- 5.3.1 Mount the relevant element as per 5.2.1 on a rigid foundation.
- 5.3.2 Attach the anchor device to the load application device and apply a load in the direction/s of load as per the manufacturer's instruction for at least 3 minutes equivalent to:
- 2,0 kN for one person;
 - 3,0 kN for two persons
- 5.3.3 Confirm that the load is not released whilst attached to the anchor device.

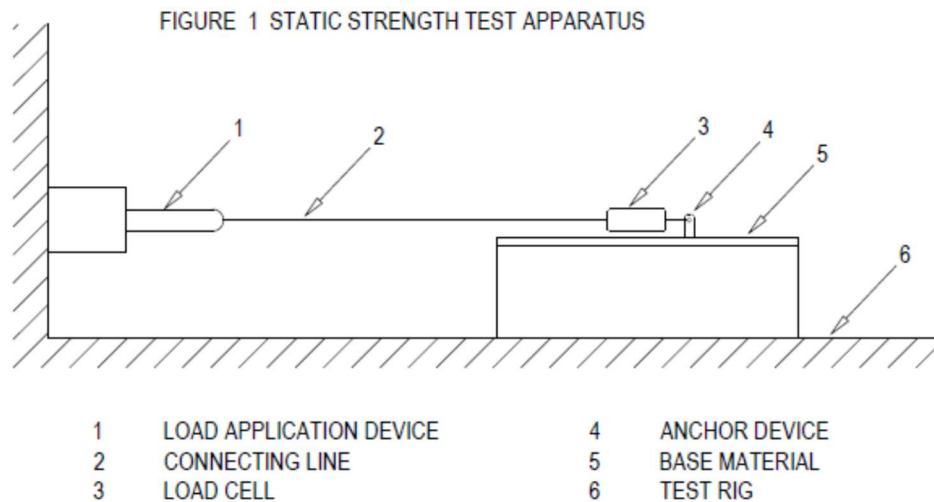

5.4 Horizontal flexible anchor lines

- 5.4.1 Install the anchor systems in/on a solid foundation (concrete or rigid steel structure) that will remain rigid and stationary during the testing procedure.
- 5.4.2 Arrange the test configuration taking into account the in-service loading direction, the span length and the combination of components / elements such as energy dissipaters, terminations, intermediate anchors and travellers.

5.5 Single span

- 5.5.1 Install the system to manufacturer's longest permissible span on the rigid foundation.
- 5.5.2 Install a load cell at each end of the line so that the tension at the extremity anchors can be measured.
- 5.5.3 If permitted by the manufacturer, install a load limiting device/s between the load cell and the anchor line. Adjust the line's pre-tension.
- 5.5.4 Attach a load cell to the traveller and locate it at mid-span. Refer Figure 2

FIGURE 2 SINGLE SPAN HORIZONTAL ANCHOR LINE

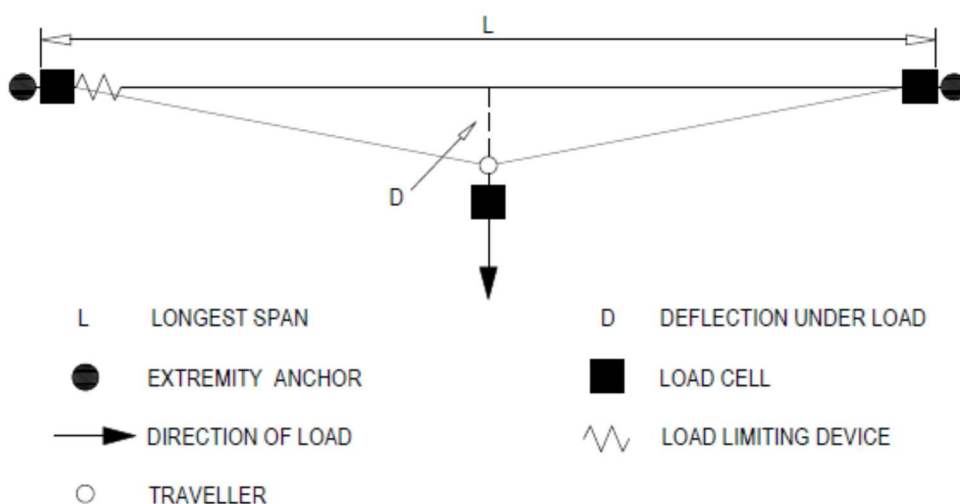

- 5.5.5 Apply a static load of 0,75 kN for a single user system or 1,5 kN for the two-person system to the traveller in the intended in-service loading direction. Maintain that load until the system has come to rest.
- 5.5.6 Record the forces on all three load cells.
- 5.5.7 Measure and record the deflection in the anchor line at midspan whilst under load.
- 5.5.8 Inspect anchor devices for deflections whilst under load and measure and record the elongation or deflection at anchor point of the load limiting device, if fitted.
- 5.5.9 Release the load and after a period of five minutes, check the entire system to ensure its integrity. Measure and record any residual sag in the anchor line and check for deformation in the anchor devices and traveller.
- 5.5.10 Remove the load cell at one end of the line, reattach the line to the anchor device and move the traveller close to (within 500mm) that extremity anchor. Repeat the test described in 5.5.5 above whilst under load for 5 minutes.
- 5.5.11 Release the load and check the anchor device for any permanent damage or deflection and inspect the anchor line at the exit of the anchor device for any damage, kinking or sheared /broken wires.
- 5.5.12 Install the system to the manufacturer's shortest span and repeat the tests described in 5.5.2 to 5.5.11. The tension forces in the extremity anchors should be less than those measured in the longest span configuration.
- 5.5.13 **DATA -**
 - 5.5.13.1 Maximum span lengthM
 - 5.5.13.2 Maximum Tension at extremity anchor on longest span: - kN
 - 5.5.13.3 Confirm static load at traveller: - kN
 - 5.5.13.4 Maximum mid-span deflection under load: -mm

5.6 Multi-span

General

Install the system on a rigid foundation (concrete or rigid steel) in accordance with the information supplied by the manufacturer, consisting of at least two spans of unequal length. The longest and shortest permitted by the manufacturer. If the manufacturer offers a corner configuration for the anchor line, install a 90 degree corner between the two spans.

- 5.6.1 The first test is on the longest span.
- 5.6.2 Install a load cell at each end of the line so that the tension at the extremity anchors can be measured.
- 5.6.3 If permitted by the manufacturer install a load limiting device at the one end between the load cell and the anchor line. Adjust the line's pre-tension.
- 5.6.4 Attach a load cell to the traveller and locate it at mid-span. **Refer Figure 3**

- 5.6.5 Apply a static load of 0,75 kN for a single user system or 1,5 kN for the two-person system to the traveller in the intended in-service loading direction. Maintain that load until the system has come to rest.
- 5.6.6 Record the forces on all three load cells.
- 5.6.7 Measure and record the deflection in the anchor line at midspan whilst under load.
- 5.6.8 Inspect anchor devices for deflections whilst under load and measure and record the elongation or deflection at anchor point of the load limiting device, if fitted.
- 5.6.9 Release the load and after a period of five minutes, check the entire system to ensure its integrity. Measure and record any residual sag in the anchor line and check for deformation in the anchor devices and traveller.
- 5.6.10 Replace any element that has suffered deformation, adjust the pre-tension to the predetermined load and locate the traveller at mid-span on the shortest span.
- 5.6.11 Repeat steps 5.6.2, 5.6.3, 5.6.4, 5.6.6, 5.6.7, 5.6.8, and 5.6.9
- 5.6.12 Remove the load cell at one end of the line, reattach the line to the anchor device and move the traveller close to (within 500mm) that extremity anchor. Repeat the test described in 5.5.5 above whilst under load for 5 minutes.
- 5.6.13 Release the load and check the anchor device for any permanent damage or deflection and inspect the anchor line at the exit of the anchor device for any damage, kinking or sheared /broken wires.
- 5.6.14 **DATA**
 - 5.6.14.1 Bay Length (longest span)M
 - 5.6.14.2 Maximum Tension at extremity anchor: - kN
 - 5.6.14.3 Confirm static load at traveller: - kN
 - 5.6.14.4 Maximum Deflection under load: -mm

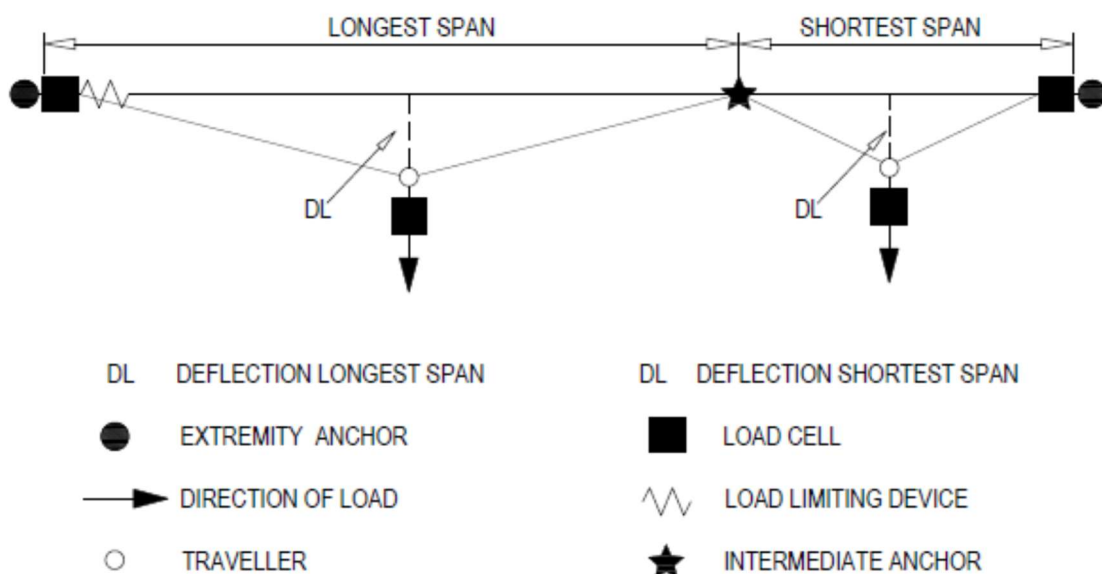

FIGURE 3 MULTI-SPAN HORIZONTAL ANCHOR LINE

5.7 Static load test on base material (roof sheeting)

5.7.1 Horizontal forces applied to sheeting needs to be tested in two directions, parallel to the sheeting ribs and perpendicular to ribs. Profilers to specify maximum purlin spacing for fall restraint systems and to which narrow flutes (centre flutes or side-lap flutes) anchor base plates can be fixed to.

5.7.1.1 Concealed-fix sheeting

Parallel testing determines -

- a. The load at which the sheeting will slide over the concealed-fix clips which are designed to allow for parallel movement/sliding to accommodate thermal movement.

Determine the sheet length and purlin spacing that requires positive fixing of the sheet to which the anchor is fixed when at least three sheets are installed side by side. The profiler must specify sheets lengths and purlin spacings that will not require positive fixings.

- b. The slipping /dislodging loads of equipment fixing clamps (commonly referred to as PV clamps).

Determine the maximum load that fixing clamps can be subjected to individually and in groups of more than one clamp per sheeting rib or base plate fixed to more than one sheeting rib.

Both parallel tests (sheet slipping vs PV clamp failure) need to confirm the required load of the fall restraint anchor system can be met with-out residual damage to the sheeting rib or paint surface when the fixing clamp is removed.

The profiler / supplier must determine the placement (minimum distances) of the anchor base plate with respect to purlin clips so as not to restrict thermal expansion movement between the sheeting and its securing clips.

Perpendicular testing determines-

- a. The loading that can be resisted with-out the fixing clamp disengaging from the sheeting rib. No slipping and disengagement are allowed.

Determine whether the specified load can be achieved with-out residual damage to the profile and paint coating when the fixing clamp has been removed

- b. The loading that can be resisted when fixing clamps are attached to more than one sheeting rib, typically when fixing clamps at the corners of a base plate are attached to adjacent ribs.

Determine whether the upward and downward forces at sheeting ribs due to the rotation of the base plate can be resisted when the specified load has been achieved with-out residual damage to the profile and paint coating when the fixing clamps has been removed.

5.7.1.2 Pierced-fix sheeting

Parallel and perpendicular testing are required to determine whether the specified loads can be resisted on the sheeting in both directions (3 sheets installed side by side over at least two purlins) and the use, quantity, and limitations of mechanical fixings to the sheeting for the anchor base plates.

Determine whether the specified load can be achieved with fixing to the sheeting ribs only and whether fixing to side laps are allowed or whether positive fixing through the sheeting into the supporting structure should be used.

- 5.7.2 Install approved base material (SABS approved roof sheeting of the correct profile and material thickness) and approved supporting structure (purlins of the minimum allowable size and thickness) using approved cleats / brackets onto the test rig. Refer Figure 1.
- 5.7.3 Determine the mass of any element of the anchor system that is intended to be carried by a single person by weighing.
- 5.7.4 Install the extremity anchor in accordance with the manufacturer's instructions onto the sheeting and secure as per the sheeting profiler's agreed method of attachment.
- 5.7.5 If the sheeting profile is of the concealed fix type that relies on frictional grip over more than a single clip on a single purlin, the rig must be long enough to accommodate the number of purlins spaced according to the sheeting profiler's requirement.
- 5.7.6 If the sheeting profile relies on more than a single roof sheet in width, the rig must be wide enough to accommodate at least three sheets with their side laps properly assembled.
- 5.7.7 The test rig shall be in a horizontal position and at a working level to facilitate test loading and evaluation.
- 5.7.8 Apply a static load as determined in 5.5.13.2 or 5.6.14.2 to the anchor point of the extremity anchor in the intended in-service direction and maintain that load for at least 3 minutes.
- 5.7.9 Confirm that the load is not released whilst attached to the anchor device.
- 5.7.10 Release the load and confirm that the sheeting and its supporting structure remains intact without any visible signs of damage or displacement.

5.8 Horizontal Rigid Rails

Rigid rails are designed to restrict deflection to within the elastic range of the material and are generally used as overhead, fall arrest, rope access or suspended access monorails but could be employed as fall restraint systems. For use on fluted metal roofing the same loading restrictions as for static anchor points will apply.

5.8.1 Deformation test

- 5.8.1.1 Mount a representative length of rail on a solid substrate (concrete or steel) with at least three rail support brackets spaced to the maximum spacing allowed by the manufacturer.
- 5.8.1.2 Fit the manufacturer's approved trolley to the rail and insert or fit the approved stop ends.
- 5.8.1.3 Subject the rail to a static load of 0,2 kN for a single user or 0,3 kN for two users at mid-span for a minimum period of three minutes in the direction of load as per the manufacturer's instruction.

- 5.8.1.4 Release the load and measure for deformation or deflection of the rail and its support brackets.
- 5.8.2 **Static load test on base material (roof sheeting)**
- 5.8.2.1 Install approved base material (SABS approved roof sheeting of the correct profile and material thickness) and approved supporting structure (purlins of the minimum allowable size and thickness) using approved cleats / brackets onto the test rig. Refer Figure 1.
- 5.8.3 Determine the mass of any element of the anchor system that is intended to be carried by a single person by weighing.
- 5.8.4 Install a short length of the anchor rail in accordance with the manufacturer's instructions onto the sheeting and secured as per the sheeting profiler's agreed method of attachment. Fit an approved trolley and end stops to the rail.
- 5.8.4.1 If the sheeting profile is of the concealed fix type that relies on frictional grip over more than a single clip on a single purlin, the rig must be long enough to accommodate the number of purlins spaced according to the sheeting profiler's requirement.
- 5.8.4.2 If the sheeting profile relies on more than a single roof sheet in width, the rig must be wide enough to accommodate at least three sheets with their side laps properly assembled.
- 5.8.5 The test rig shall be in a horizontal position and at a working level to facilitate test loading and evaluation.
- 5.8.6 Locate the trolley directly over an attachment bracket and apply a load in the in-service direction for at least 3 minutes. The load shall be equivalent to:
- 0,75 kN for one person.
 - 1,5 kN for two persons
- 5.8.7 Confirm that the load is not released whilst attached to the trolley.
- 5.8.8 Release the load and confirm that the sheeting and its supporting structure remains intact without any visible signs of damage or displacement.
- 5.8.9 Relocate the trolley to mid-span and repeat the load test/s
- 5.8.10 Confirm that the trolley and its load remain intact.
- 5.8.11 Release the load and confirm that the sheeting and its supporting structure remains intact without any visible signs of damage or displacement.
- 5.8.12 If a cantilever is permitted by the manufacturer, repeat the static test at the maximum distance on the unsupported rail. Observe and record the maximum deflection of the rail. Such deflection shall not exceed $l/250$ of the cantilevered length and remain within the elastic range of the material.

6 Installation

Fall restraint systems are to be installed on fluted metal roofing, located and positioned, together with appropriate personal protective equipment, such that the users cannot reach a fall risk position. All anchor points or anchor lines need careful planning and only personal protective equipment with lanyards of the correct length

as specified by the supplier or manufacturer may be used.

The fall protection plan compiled by a competent person as envisaged in the regulations attached to the Occupational Health and Safety Act, must address at least the following aspects: -

- 6.1 Additional measures that might be required where access to and egress from the fall restraint system exposes the user to a fall risk whilst transitioning the immediate area on a roof from the access point such as a ladder, to the start point of fall restraint system. Such measures could include guardrails, barricades, screens, anchorages or similar equipment as appropriate.
- 6.2 Take into account the additional distance that the user can reach whilst attached to the horizontal flexible anchor line system as measured during the “maximum deflection” static test to ensure that user cannot reach the fall risk zone.

7 Securing methods

- 7.1 All fixings between roof sheeting and anchor systems shall be of a positive type such as screws, bolts, clamps or rivets. Resin or other forms of chemical adhesives shall not be used due to the differential rate of thermal expansion between the thin sheeting and the thicker base plate materials can cause a shearing action between the metal elements.
- 7.2 Any fixing method between the anchor system and the roof sheeting must be approved by the manufacturer and the sheeting profiler to ensure that the necessary thermal expansion of the sheeting and related flashings is not impeded.
- 7.3 Special attention must be given to securing the anchor system to services and installations such as photo-voltaic panels, ventilators, smoke extraction fans and the like where the additional fall protection loads on the fixings of these elements might not have been designed for. Any such attachment must be approved by the building owner and/ or the services supplier/s.
- 7.4 Any fixing method must allow for the designed deflection of the sheeting profile where such upwards deflection caused by wind forces is required to lock or otherwise improve the side-lap connection between rows of sheeting.

8 Information to be supplied

The fall restraint system needs to be accompanied with comprehensive documentation to ensure its safe use and should include at least the following information regarding:

- 8.1 The maximum number of simultaneous users. This must also be permanently and prominently displayed next to each access point of the fall restraint system.
- 8.2 The maximum length of lanyards and the type of personal protective equipment that may be used.

- 8.3 Minimum level of training of the users and contact details of recommended training provider organisation/s or relevant professional bodies that recognises such training providers.
- 8.4 The address and location of the installation and the name and address of the installation company.
- 8.5 Pro-forma check lists for the periodic examination and routine inspections and the required competence or professional designation of the person that can undertake these examinations and inspection.
- 8.6 Warning regarding modification of the system by third parties without the written approval of the manufacturer / supplier / installer of the system.
- 8.7 Lock-out procedure and notification if the system is deemed to be unsafe.

9 Documentation control.

- 9.1.1 After installation, copies of all necessary documentation including user instructions and pre-use inspection procedures and pro-forma check lists must be handed over to the building's responsible person, facilities manager, building maintenance manager or representative of the building owner in hard copy or electronic format as required by the recipient. Copies of all documentation to be kept by the installer / supplier of the fall protection system.
- 9.1.2 If the installation activity is considered construction work, then the requirements of the regulations covering construction work and all necessary safety documentation as per the regulations shall be complied with.

10 Determination of Base Static Loads for Fluted Metal Fall Restraint Systems

10.1 Scope and purpose

This section establishes the design basis, load definitions and calculation principles for permanent fall restraint systems installed on fluted metal roof sheeting in South Africa. It provides a nationally appropriate, performance-based framework for determining fall restraint loads that are:

- consistent with the Occupational Health and Safety Act (85 of 1993)
- aligned with the hierarchy of controls prescribed in the Construction Regulations 2014
- compatible with the structural limitations of locally installed fluted metal roof sheeting and;
- explicitly differentiated from fall arrest loading conditions.

This section **only applies to fall restraint and work positioning systems** as defined in EN363 and **excludes fall arrest systems**.

10.2 Regulatory and Design Philosophy

- 10.2.1 In terms of section 8 of the Occupational Health and Safety Act (85 of 1993), employers and designers shall ensure that work at height risks are reduced as far as is reasonably practicable.
- 10.2.2 Construction Regulation 10 requires that fall prevention and fall restraint measures are prioritised above fall arrest systems.
- 10.2.3 Designers are required, in terms of Construction Regulation 6, to eliminate hazards at source or, where this is not reasonably practicable, to mitigate such hazards through engineering controls.
- 10.2.4 In fulfilment of these duties, restraint systems installed on fluted metal roof sheeting shall **not be designed for fall arrest loads**, as such loads are not representative of restraint use and are incompatible with the load-bearing capacity of typical metal roof sheeting systems used in South Africa.

10.3 Relevant Definitions (for the purpose of section 10)

fall restraint system

Personal fall protection system that prevents the user from reaching zones where a fall from height can occur.

design static load (DSL)

The static design action applied to an anchor point or anchor system for the purposes of structural verification under restraint conditions.

characteristic restraint load

The representative static load generated by one or more users under fall restraint conditions, excluding fall arrest effects.

pre-tension load

The initial tensile force applied to a flexible anchor line to remove slack and reduce some of the constructional stretch prior to service.

10.4 Basis for load Determination

- 10.4.1 Loads arising from fall restraint systems are considered **static or quasi-static actions**.
- 10.4.2 Free fall conditions are not permitted in restraint systems. Thus, dynamic amplification associated with fall arrest shall not be applied.
- 10.4.3 The Characteristic Restraint Loads defined in this standard are derived from body weight, posture and movement while restrained including minor transient load effects associated with the tensioning of the restraint lanyard. These loads are verified by various tests described herein under.
- 10.4.4 The Characteristic Restraint Loads are aligned with the intent of restraint testing in European standards adapted for South African conditions.

10.5 Characteristic Restraint Loads

The following characteristic restraint loads (F_k) shall be used for design

Number of simultaneous users	Characteristic restraint load Fk
1	0,5 kN
2	1,0 kN

NOTE: These loads represent restraint conditions only and shall not be used where fall arrest may occur.

10.6 Partial Safety Factor and Design Static Load

10.6.1 A partial safety factor (γ) shall be applied to the characteristic restraint load to account for variability in user mass; uncertainty in load application; minor dynamic effects associated with movement.

10.6.2 For fall restraint systems on fluted metal roof sheeting, a partial safety factor $\gamma = 1,5$ shall be used.

10.6.3 The design static load (DSL) shall be calculated as:

$$DSL = \gamma \times F_k$$

10.6.4 The resulting design static loads shall be taken as:

1 user	0,75 kN
2 users	1,5 kN

These loads shall form the minimum design basis for anchor devices and anchor systems.

10.7 Application of Flexible Anchor Line Systems

10.7.1 Flexible anchor lines (Type C systems) shall be designed such that the restraint loads applied at mid-span do not result in excessive forces at extremity anchors.

10.7.2 The relationship between mid-span load, sag angle and extremity anchor tension shall be explicitly considered during design.

10.7.3 All extremity forces must be compatible with the allowable loads stipulated by the sheeting profiler. Any design of a fall restraint system must respect the capacity of the sheeting.

10.8 Calculation of Extremity Anchor Forces

10.8.1 The tensile force at each extremity anchor shall be calculated as;

$$T_{\text{end}} = (DSL / (2 \times \sin \theta)) + T_{\text{pre}}$$

Where T_{end} is the design tensile force at the extremity anchor (kN); DSL is the design static load applied at mid-span (kN); θ is the sag angle generated under DSL; T_{pre} is the pre-tension load in the anchor line (kN).

10.8.2 Pre-tension loads are added algebraically to restraint induced forces.

10.9 Pre-Tension Loads

10.9.1 Pre-tensioning of flexible anchor lines is required to remove slack and to some of the constructional stretch.

10.9.2 Pre-tensioning loads for restraint systems shall be significantly lower than those used for fall arrest systems and shall be set during normal ambient day-time temperatures.

10.9.3 Unless otherwise justified by testing, the following pre-tension loads shall be used:

- Ropes up to 10m long with bay lengths of max 5m: 0,2kN
- Ropes longer than 10m up to 25m, with bay lengths of max 5m: 0,25kN and with bay lengths up to 7m: 0,3kN.
- Ropes longer than 25m up to 40m with bay lengths of max 5m: 0,3kN and with bay lengths up to 7m: 0,35kN.
- Ropes longer than 40m - bay lengths of 5m: 0,35kN and bay lengths up to 7m: 0,4kN.

10.10 Limitations Related to Fluted metal Roof Sheeting

10.10.1 Fluted metal roof sheeting has limited capacity to resist concentrated point loads.

10.10.2 Where calculated extremity anchor forces exceed the maximum allowed by the sheeting profiler, anchor devices shall not be fixed directly to the sheeting unless additional structural support is provided or loads are redistributed via multiple support points.

10.10.3 Where this limit cannot be met, alternative systems such as single-point anchors (Type A) or rigid rails (Type D) as described in EN795, which eliminates the amplification factor of flexible anchor lines, might be appropriate.

10.11 Exclusion of Fall Arrest

10.11.1 Systems designed in accordance with this section are **not suitable for fall arrest** .

10.11.2 Fall arrest systems shall be designed and tested in accordance with applicable fall arrest standards and shall not rely on fluted metal roof sheeting as the primary load-bearing substrate.

10.12 Compliance Statement

A fall restraint system designed in accordance with this protocol shall be deemed to satisfy the requirements of South African Occupational Health and Safety legislation, provided it is installed, inspected and maintained as intended by design.

11 Establishing restraint load.

The following testing procedures apply:

An adult male person with a height of approx. 1,77m with a body mass of $\pm 90\text{kg}$ will be selected to perform the restraint load test. The person will wear a full body harness (EN361) attached to a lanyard (EN354) secured to the Dorsal "D" ring.

The other end of the lanyard is connected to a load cell (with a range of 50kg up to 250kg) which in turn is connected to a static anchor point with a certified resistance of at least 6 kN.

The vertical position of the anchor point must be changeable from $\pm 1,5\text{m}$ to $\pm 200\text{mm}$ above the walking surface. This is to simulate conditions for a standing person or a person working whilst kneeling. The walking surface is at a low slope away from the anchor point set at 3 degrees to simulate typical slopes on roofs clad with concealed-fix sheeting.

- 11.1 With the lanyard slightly slack, i.e. allowing free movement of 1,5m before reaching full tension and the anchor point at its high level, the person walks towards the danger zone whilst slightly stooping at nominal velocity of 0,5 to 0,7mps. carrying a test weight of 25kg in front of him This translates into a movement time of about 1,0 to 1,5 seconds. When stopped (probably with one foot still in the air), the person places both feet on the surface and leans forward so as to apply a load into the lanyard by reaching forward with the test weight. The restraining load is recorded, and the test is repeated five times with rest periods of at least three minutes between tests. **Refer figure4**

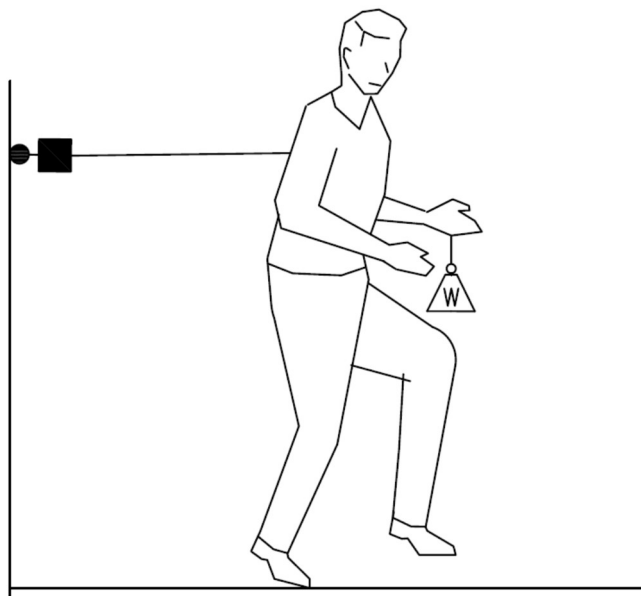

FIGURE 4

- 11.2 Repeat the test but with the anchor point at its low level and record the results. The average of the two highest loads is taken as the restraint load. **Refer figure 5**

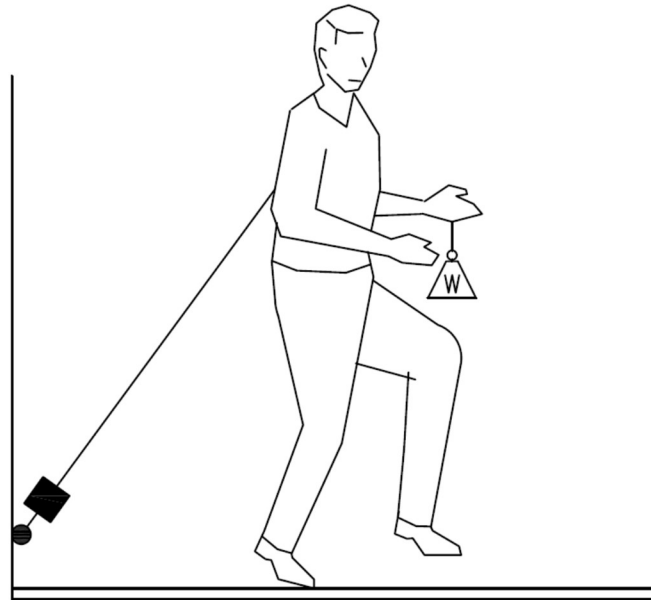

FIGURE 5

11.3 Repeat the above test but place the person on a sloping surface of 12 degrees. This simulates a pierced-fixed sheeted industrial roof. Repeat and record the results of the two tests 5 times each. Use the average of the two highest results. Refer **figures 6 and 7**

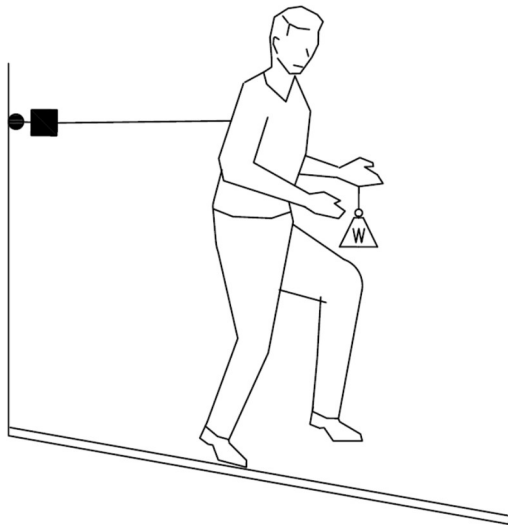

FIGURE 6

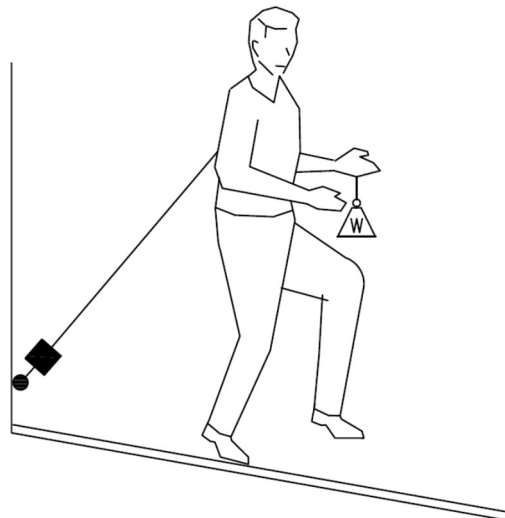

FIGURE 7

11.4 Next test is with the person crawling towards the danger zone and the anchor point firstly at the high level and then at the low level. When the lanyard becomes taught the person picks up the test weight (which was placed on the deck in front of him) with one or both hands. Compare the average of the two highest loads with those measured above. Use the highest load as the final restraint load for a flat surface. Refer **figures 8 and 9**

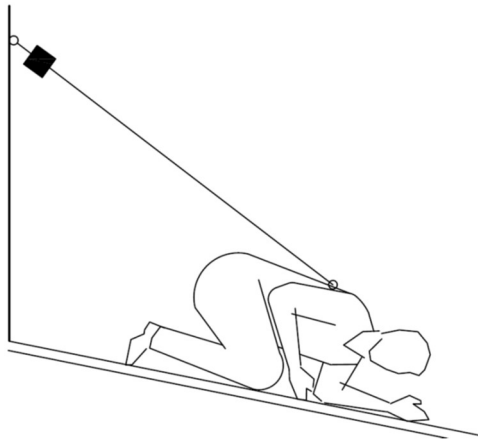

FIGURE 8

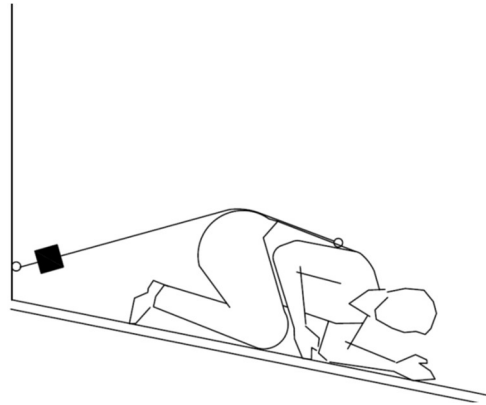

FIGURE 9

Characteristic Fall Restraint Load (see section 10 above) for one person: The above tests were carried out, observed and approved on the 24th April 2026.

The agreed Characteristic Fall Restraint Load amounts to: **0,5 kN**